



Micromate Plus™

Operator Manual

Table Contents

Micromate Plus	4
About Us	5
Customer Support and Contact Information	6
Product Warranty	7
Intended Use	8
EC Warning	8
Cybersecurity	8
Waste Management Directive	8
1. Before You Begin	9
1.1. Check the Package Contents	9
1.2. Record the Identification Numbers	9
1.3. Complete Your Registration	9
1.4. Handling Precautions	10
1.5. Cleaning the Micromate Plus	10
2. Understanding the Micromate Plus	11
3. Range of Applications	14
4. Using the Keypad	15
5. Quick Start - Basic Tutorial	16
6. Battery Overview	21
6.1. Battery Life and Temperature	21
6.2. Charging the Batteries	22
6.3. Battery Shipping Instructions	22
7. Quick Start Guide	23
7.1. Common Key Functions	23
7.2. Recording Set Up	24
7.3. Edit Setup and Setup Sensors	25
7.4. Perform a Sensor Check	27
7.5. Start or Stop Monitoring	28
7.6. View or Delete Events	28
7.7. Set Up Personal Preferences	29
7.8. Unit Maintenance	32
8. Specifications	32
8.1. General Specifications	32
8.2. Geophone Specifications	32
8.3. Microphone Specifications	33
8.4. Recording	33
8.4.1. Waveform Recording	33
8.4.2. Histogram Recording	33
8.5. Physical Specifications	34
9. Enclosing the Unit in a Box	34
9.1. Recommended Connectors	34



Micromate Plus™

Congratulations on your purchase!

The Micromate Plus monitoring unit provides rugged, reliable monitoring with a built-in modem for cellular and wireless connectivity. Swap any Micromate Plus geophone with any Micromate Plus base unit. This total flexibility alleviates calibration downtime. Configure your unit in the field with the fail-safe keypad, even if cellular coverage is unavailable. The robust connectors permit easy handling while wearing gloves. The Micromate Plus offers flexible data retrieval – directly from the unit using a USB-C thumbdrive, uploaded via a wireless connection and our cloud-based Vision II software platform, or by directly connecting a computer.

Only the accessories require calibration, not the unit, allowing the Micromate Plus to remain in service for other projects. With an additional geophone inventory, you can easily swap out your geophone with one that is already calibrated and avoid downtime. Each geophone is configured to a full spectrum of industry standards, including ISEE and DIN, to ensure you can use it in multiple locations for multiple projects. With Vision II software, easily toggle between one standard and the next as your project requirements change. Each geophone has the option for floor and/or wall-mount installation.

Multiple configurations are possible on the Micromate Plus – three channels for a triaxial geophone, one channel for a sound level microphone, one channel optimized for audio and one channel for an ISEE linear microphone.

About Us

For over 40 years, InstanTel has been a global leader with best-in-class vibration, noise and air overpressure equipment for quarries, mining, construction, civil, geotechnical and other applications. Our products have contributed to the success of our customers' projects in over 85 countries and on countless sites. From specialized sensors and recording options, to remote data collection and a cloud-based data hosting solution, InstanTel provides solutions that work.

We are proud of our position as an industry leader, boasting many industry firsts, but it does not stop there. We are committed to continuous improvement through innovation. We understand that our customers face challenging environments daily and need reliable data fast to ensure the success of their projects. We specialize in providing the tools that complete each project safely, quickly, and within compliance.

Our flexible product portfolio allows our customers to select the monitoring solution that best meets their needs - whether deep in the earth, above ground, or underwater.

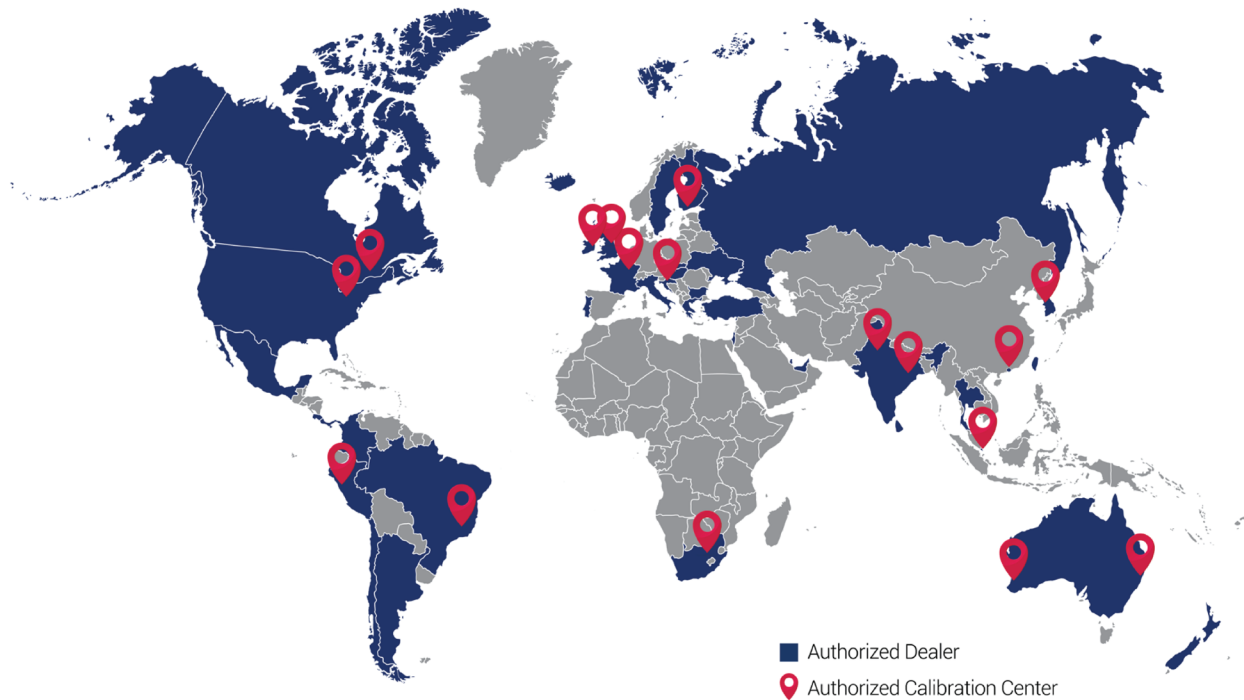



A worldwide network of qualified Dealers offers Instantel equipment sales and rentals, as well as professional consulting, monitoring and support services, for any project. Instantel Dealers receive factory direct training on products and technical support.

Instantel instruments are precisely calibrated and sealed with a “tamper” label at the factory prior to shipping. The tamper label safeguards against unauthorized access to the internal components. The accompanying calibration report includes the actual amplitude verses frequency response graph for the microphone and/or sensor shipped with the unit. It is recommended that sensors and microphones are re-calibrated on an annual basis, either at Instantel or at factory authorized calibration and service sites.

Events from the Micromate Plus unit can be forwarded to Vision II, our cloud-based vibration monitoring data hosting application that takes the pain out of satisfying even the most demanding reporting requirements.

Data retrieval is effortless—from the unit itself using a USB-C, a direct connection to a computer, or using Vision II, our cloud-based software system. Monitor vibrations in near real time with Live Data, a feature of Vision II. Vision II provides secure, encrypted cloud-based access to the latest information from any desktop, laptop, tablet or cellular device with access to the web.

Instantel products have become known for world-leading reliability, ruggedness and ease of use. While full featured, we feel our units also represent the best available value in the industry. Instantel works closely with local and global suppliers and our own teams to ensure products are in stock and available when you need them. We strive to provide the best and most responsive technical support in the industry. All of this means that when you purchase Instantel products, you are purchasing the best!

Customer Support and Contact Information

USA Customers:
808 Commerce Park Drive
Ogdensburg, NY 13669 USA

International and Canadian Customers
309 Legget Drive
Ottawa, Ontario, Canada K2K 3A3

For sales, customer support, to locate an authorized calibration site, or for other inquiries:

Telephone	1.613.592.4642
Toll-Free	1.800.267.9111 (North America only)
Technical Support	1.613.592.4642

Technical Support Email	service@instantel.com
General Inquiries	sales@instantel.com

Web	www.instantel.com/calibration-sites
-----	-------------------------------------

Product Warranty

Instantel products come with a limited one-year warranty against defects in materials or workmanship unless otherwise stated. The warranty begins on the date of shipment from the Instantel factory to the customer and is subject to certain exclusions and conditions as stated in the product warranty information found on our website at:

<https://www.instantel.com/service-and-support/warranty-form>

Alternatively, use the QR code for a direct link to our warranty statement.



Intended Use

This is an electronic instrument. Although it has been designed for field use, it contains sensitive components which cannot be expected to withstand the same stress and shock as construction tools or heavy machinery. It contains a microcomputer and solid state memory, both of which may be made inoperative by severe radio interference. The use of transmitting equipment in the immediate vicinity of the unit should be avoided. Its intended use is for the collection, transmission, and logging of sensor-generated data. It is designed for field monitoring and analysis for industrial, commercial, and research environments. Evidence of negligence in the care or handling of the instrument may void the manufacturer's warranty. This product contains no serviceable parts. The battery is not intended to be replaced by the operator. The unit should be returned to an authorized InstanTel service center for service. Any attempt to service this product will void any and all warranties offered by InstanTel. Service inquiries should be made via your dealer. If the equipment is used in a manner not specified by the manufacturer, the protection provided by the equipment may be impaired.

Use of this device must comply with all applicable regulatory requirements and standards. Any unauthorized use, including modifications or applications beyond the scope specified in the product documentation, may affect the accuracy, reliability, and safety of the device and void the warranty.

EC Warning

This is a CE Class A product that has been tested to and passed the IEC 61010-1 (CE test report available from InstanTel). If this product is not used as outlined within this manual, it may cause radio interference.

General Warning

Read and understand all safety instructions before operating this equipment. Failure to follow the safety precautions and warnings described in this manual may result in electric shock, fire, personal injury, or equipment damage.

All caution, warning, and danger messages in this manual are provided to protect the user and ensure reliable operation of the product.

Always observe the safety symbols and heed all warning labels affixed to the unit.

Cybersecurity

This device includes internal Wi-Fi and cellular modems. While using modems, safe security measures should be undertaken, such as strong, unique passwords.

Waste Management Directive

For European Union (EU) countries, this product must be collected and discarded separately from household waste. Mindful of the environment, InstanTel has adopted the Waste Electrical and Electronic Equipment Directive (WEEE). This product contains electrical or electronic materials, including batteries. These materials can have adverse effects on the environment and human health if not disposed of properly. The WEEE label on the product means it should not be disposed of as unsorted waste and must be collected separately from household waste, as per legislation under the WEEE Directive.

As a consumer, you are responsible for ensuring that this product is disposed of properly. Please get in touch with your local waste management facility for instructions.

1. Before You Begin

To ensure your Micromate Plus is ready for operation and to ensure successful registration for the InstanTel Product Support Program, please complete the following steps:

1.1. Check the Package Contents

Please check that you received all the parts identified on your shipping invoice. Remember to keep your shipping box because it was designed to safely ship your monitor back to InstanTel for calibration and service.

1.2. Record the Identification Numbers

Record the following identification numbers for future reference:

1.3. Complete Your Registration

Unit Serial Number	
Geophone Serial Number	
Linear Microphone Serial Number	
Sound Level Microphone Serial Number	
Dealer Name	
Date Purchased	

You must complete the registration by email within ten (10) days of purchasing your new unit. You may also register your product online at: <https://www.instanTel.com/service-and-support/warranty-form>.

1.4. Handling Precautions

The triaxial geophone is calibrated using a baseline method across a frequency range of 1 to 500 Hz on each channel, maintaining a tolerance within 5% of the nominal zero value. Software controls allow users to switch between different compliance standards, including the North American International Society of Explosives Engineers (ISEE) and the Deutsches Institut für Normung (DIN 45669-1) without re-calibration. The geophone's phase response meets the vibration requirements of both the ISEE and DIN 45669-1 standards.

Sound level microphones are calibrated to the IEC 61672 Class 1 standard, while the linear microphone follows the ISEE Performance Specifications for Blasting Seismographs (ISEE-2022).

The Micromate Plus system is designed with modularity in mind—the sensors are not permanently paired with the base unit, allowing them to be used interchangeably across multiple Micromate Plus units.

General Handling Precautions

- Handle all equipment and accessories with care.
- Do not operate the equipment if the enclosure is damaged. Immediately turn the instrument off and have it inspected by an authorized InstanTEL repair facility.
- Use only the recommended InstanTEL AC adapter. Alternate power sources may incorrectly set polarity, cause overheating and/or distortion, fire, electrical shock, or other hazards.
- Ensure that the AC adapter is fully inserted and rated for the AC supply voltage of the outlet.
- To ensure proper operation, charge the battery immediately when the Micromate indicates a low battery condition. The Micromate can remain on charge without damaging the battery.
- The battery may present a fire or chemical burn hazard if mistreated. DO NOT disassemble the battery, do not heat above 100°C (212 °F), do not incinerate.
- Disconnect the battery when storing for prolonged periods or shipping by commercial courier.
- Do not open the unit.
- Ensure the connectors are clean before each use. Do not pull on the cord when connecting or disconnecting cables. Align the connector to the port before inserting. Never force a connector.
- Ensure the cable or device is attached to the proper connector.
- The Micromate Plus is rated IP68 if all sensors are connected properly and all water/dust caps are installed on unused ports.

1.5. Cleaning the Micromate Plus

To ensure your Micromate Plus unit remains in optimal condition:

Power Down: Before cleaning, turn off the device and disconnect it from any power source or network connection.

Use a Soft Cloth: Gently wipe the exterior with a soft, lint-free cloth (e.g., microfiber).

Mild Cleaning Solution (Optional): If needed, lightly dampen the cloth with water or a mild, non-abrasive cleaning solution. Avoid using alcohol, ammonia, or harsh chemicals.

Avoid Moisture Ingress: Do not spray liquids directly into the connectors.

Cleaning Connectors: For ports and connectors, use a dry, soft brush or compressed air to remove dust or debris.

Dry Before Use: Ensure the device is completely dry before reconnecting power or resuming operation.

2. Understanding the Micromate Plus

Wi-Fi Connectivity Icon

Local Time

Short Cut Icons

Quick Key Functions

Power Button



Cellular Connectivity Icon

Battery Level Icon

Navigation Buttons

Lit When Charging

Lit When Operational

Touchscreen Icons



Set up or modify parameters for event recording



Check the sensors to ensure they function as intended—fail or pass

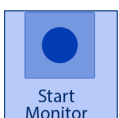

Start/stop recording the event

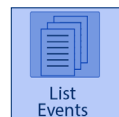

Review past events

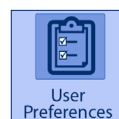

Set up general preferences, date and time, and connectivity

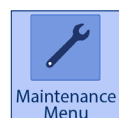

Battery Status/Self Check/About

Quick Key Functions



Check the sensors to ensure they function as intended—fail or pass



Start monitoring



Unit setup/modification



Cancel/stop action

Standard Connections

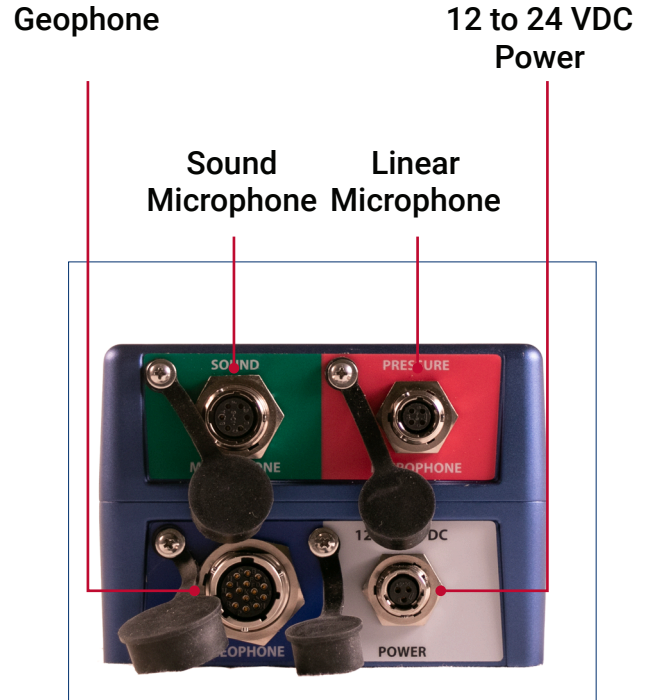
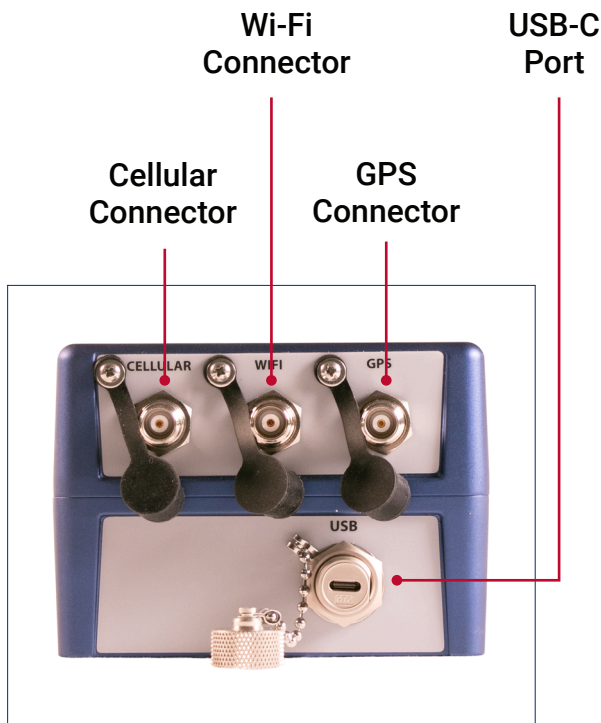

Optional Connections



AUX Port
(Factory Installed Upgrade)



Antennas (Left to Right)
340-00019-000 Cellular
340-00020-000 WiFi
340-00018-000 GPS

Product Features



1

Fail-Safe Keypad

For infield configuration when cellular connection is not available.

2

Interchangeable Geophones

Not tied to a specific base unit - swap out geophones to avoid downtime.

3

Wireless Connectivity

Built-in Cellular and Wi-Fi modems - access data 24/7/365 with Vision // software.

4

Robust Connectors

Attach sensors easily even while wearing gloves. Color coded for easy identification.

5

Flexible Data Retrieval

From the unit itself, through USB-C, or with Vision // software.



-40 to 55°C
-40 to 131°F

Wide Temperature Operating Range: Operates even in the harshest of environmental conditions, designed to handle extreme temperatures.



IP68
1.5m/5ft,
1hr

Rugged Design: Relax, knowing your unit has a field-rugged, durable design with an aluminum frame, non-corrosive connectors, and IP68 sealed electronics for additional dust and water ingress protection.

6

Channels

Channels: Channels 1 to 3: Triaxial geophone, Channels 4 to 5: Sound Level Microphone and Audio Channel, Channel 6: ISEE Linear Microphone.



QVGA
320x240

User-Friendly: View and navigate your data on a resistive touchscreen display using context-sensitive icons and an integrated keypad. The shortcut icons provide fast one-touch access to the most commonly used features.



USB-C

USB-C port: Plug-in a memory stick to easily recover your data when monitoring in remote areas where there is no access to Vision //. External charging peripherals such as off-the-shelf solar panels, or battery packs can also plug in directly to the USB port for supplemental charging.



172 Wh

Battery Life: Uninterrupted monitoring for up to 20 days. Built-in and customizable power saving modes increase the battery life depending on your configuration.



Waveform
W-Manual
Histogram
Histo-Combo

Record Modes: Select the application record mode: Waveform, Waveform Manual, Histogram, and Histogram Combo in parallel with the monitor log.



2.27 kg
5 lb

Specifications: Includes integrated carry-handles and a streamlined design with a manageable product weight.

3. Range of Applications

InstanTel vibration and overpressure monitors are amongst the most versatile seismographs available in the world. From the simplest to the most demanding applications, the Micromate Plus monitoring unit offers innovative features and multiple recording formats that increase functionality and allow for flexibility across a wide variety of applications.

InstanTel is trusted in over 85 countries with seismographs monitoring ground vibration and air overpressure changes created by blasting, demolition, mining, quarrying, and construction activities. InstanTel monitors are the instruments of choice for:



- Blast monitoring
- Construction monitoring
- Civil projects monitoring
- Dynamic compaction monitoring
- Pile driving monitoring
- Demolition monitoring
- Underground mines monitoring
- Remote access monitoring
- Oil & gas monitoring
- Tunnels & subways monitoring
- Quarries monitoring

4. Using the Keypad

The Micromate Plus monitoring unit has ten sealed, integrated keys to access menus and features:

- Four dedicated function keys:

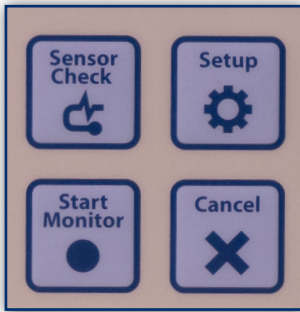

- One power button



- Four navigation keys and one checkmark key

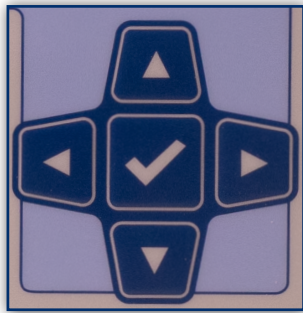

The keypad can be used in parallel with the touch screen for added flexibility. Familiarize yourself with the keypad by performing such functions as a Sensor Check. The Cancel key always exits a command or returns to the previous screen.

5. Quick Start - Basic Tutorial

In this basic tutorial, you will connect the geophone and both microphones and configure your Micromate Plus to create a sample event using the Waveform record mode. Once the event has been recorded, you will review the results on the Micromate Plus touch screen display.

Connecting the Unit to AC Power

Warning – Electrical Hazard

Improper connection to the power source can result in electric shock, fire, or damage to the equipment. Follow the instructions below carefully before connecting the unit to AC power.

- Do not use a damaged power cord or adapter. Replace immediately if the insulation is cracked or the plug is loose.**
- Do not connect the unit to power sources outside the specified range. Doing so may cause overheating or permanent damage.**
- Disconnect power before servicing or cleaning the unit.**

Step 1: Connect the Geophone and Microphones

The Micromate Plus is color-coded to make geophone and microphone attachments easy. Match the rubber end on the sensor to the connector with the corresponding color on the unit. Use the thumb grip for easy attachment. (Figure 1)

Blue—Geophone

Green—Sound Level Microphone

Red—Linear Microphone (Air Overpressure)



Figure 1

Step 2: Turn the Unit On

InstanTel and InstanTel Authorized Service and Calibration Facilities always deactivate the battery for shipping safety and battery life conservation. To activate the battery, press and hold the power button for five (5) seconds. While the operating system loads it will briefly flash the screen then display the InstanTel logo after which the Micromate Plus home screen appears.

When the battery is connected, press the power button to toggle off and on the LCD screen.

If the battery was connected previously, simply press the power button. (Figure 2) The status of your battery power is located at the top right-hand corner of the upper menu bar. The icon gives a visual with a power level indicator in percent. Example: 100%. Tap the battery icon to access more detailed information on the battery health. (Figure 3)

Note: If the battery is low, connect the Micromate Plus to AC power with the supplied charger.



Figure 2



Figure 3

Step 3: Add/Modify a Setup File

Select Recording Setup on the touchscreen or Setup on the keypad to open the Setup menu. (Figure 4)

Press the + button to create a new Setup File. Enter a Setup Name and select the Setup Type: Waveform. Default values are used to populate all fields. To edit the default values, select the existing setup or tap on the edit "Pencil" icon.

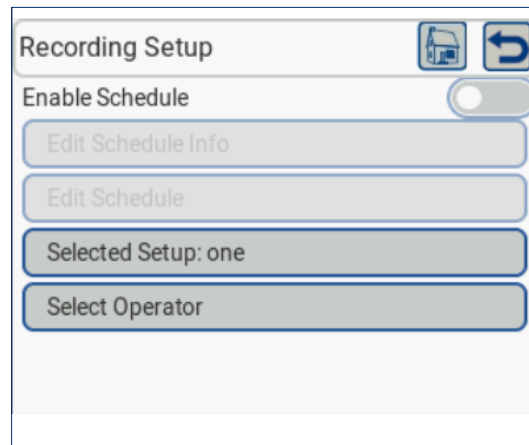

Figure 4

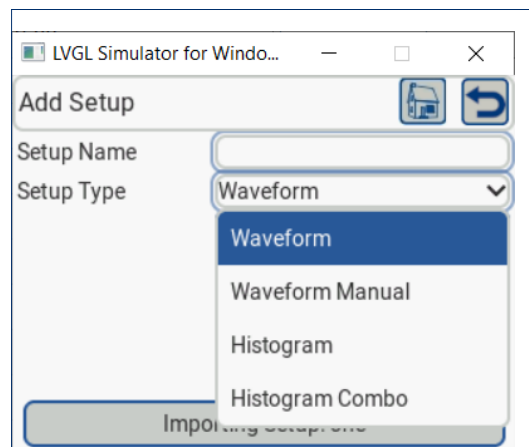

Figure 5

Step 4: Position the Sensors

Refer to Sections 13 and 15: Installing the Geophone and Microphone for additional information.

The arrows in the image indicate positive and negative ground motion which is recorded by the instrument and displayed within the Waveform Analysis window and Event Report of the Vision II software system. (see: Figure 6)

Figure 6

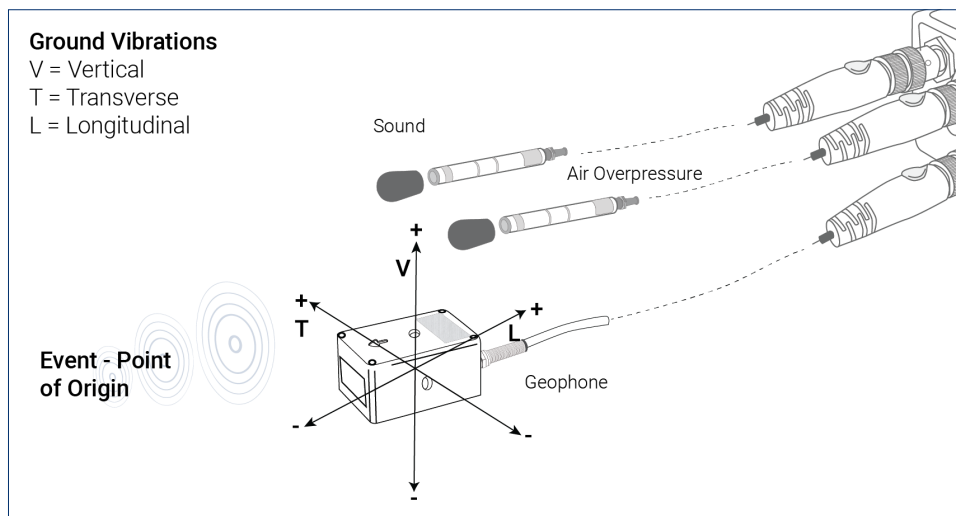

Step 5: Perform a Sensor Check

1. Confirm the sensors are properly leveled and connected to the Micromate Plus unit. Ensure cable connections are correctly seated.
2. Run Sensor Check: Press the sensor check button on the keypad or touchscreen. If the installation is good, the device will confirm that sensors are ready for monitoring by displaying a message indicating that sensors “passed”. (See: Figure 7) If any fail, verify the connection and try again.

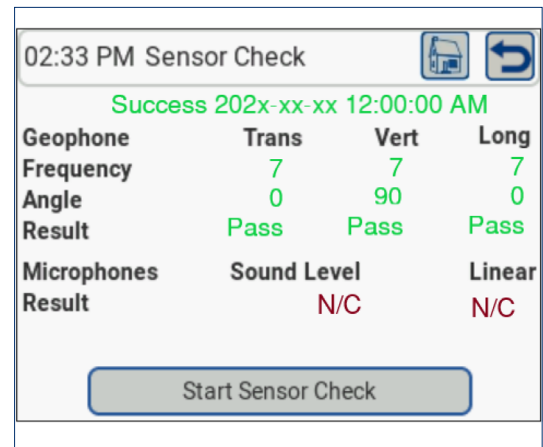

Figure 7

NOTE: Sensor Check before monitoring is always performed by the Micromate Plus. An additional option allows you to perform a Sensor Check After Event.

Troubleshooting - Geophone

If a geophone sensor check fails, a failure message appears next to one or more channels. (See: Figure 8 and 9)

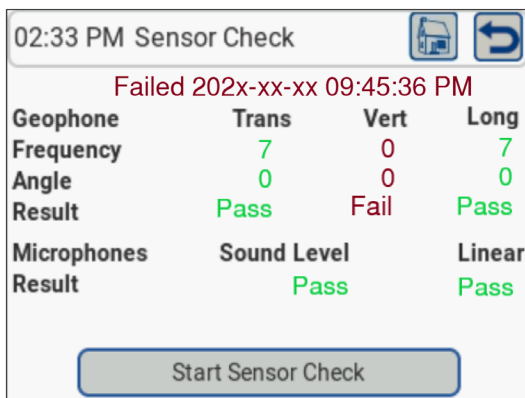

Figure 8

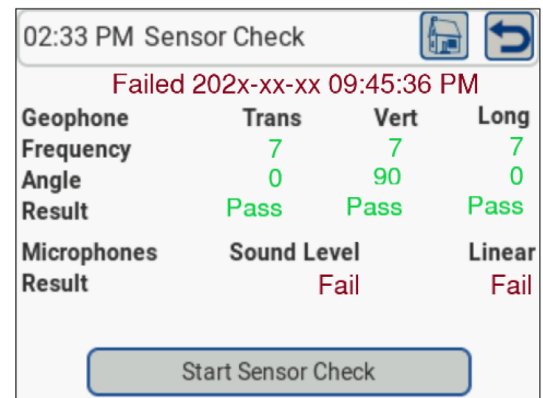

Figure 9

The most common reasons for a failed geophone sensor check are due to an improper leveling or connection. (Refer to Step 1) The geophone sensor check may also fail due to a damaged cable. Check the cable to ensure there are no cuts, crimps or any other damage. If damage exists, the cable requires replacement. If damage is evident, please contact your dealer.

⚠ WARNING: Correct any failed sensor checks before monitoring. Monitoring in a failed sensor check state could result in inaccurate data recorded on the failed channels.

In all of the following cases, ensure that the geophone is properly installed and is level.

Issue	Reason
Transverse geophone channel fails	The geophone is likely out of level from side to side.
Vertical geophone channel fails	The geophone is likely tilted from side to side, from front to back, is upside down, or some combination of these.
Longitudinal geophone channel fails	The geophone is likely out of level from front to back.

Troubleshooting - Microphones

If a microphone sensor check fails, a failure message appears in the respective microphone channel.

(See: Figure 10)

The most common reason for a failed microphone sensor check is from an improper connection. See step #1 above. The microphone sensor check may also fail due to a damaged cable. Check the cable to ensure there are no cuts, crimps or any other damage. If damage exists, replace the cable. Please contact your dealer.

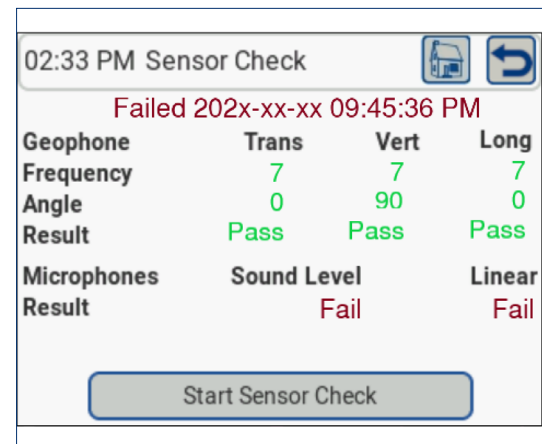

Figure 10

If the above steps do not resolve the problem, and the microphone channel continues to show a failed state, either:

1. Swap the failed microphone with another Micromate Plus microphone.
2. Disable the microphone channel to only record the other channels. See section 9.1.1 Active Sensors for instruction on how to disable the microphone.

⚠ WARNING: Correct any failed sensor checks before monitoring. Monitoring in a failed sensor check state could result in inaccurate data recorded on the failed channel.

Step 6: Record an Event

1. Press the Start Monitor key or the Start Monitor icon.
2. Wait a few seconds until the Sensor Check is complete, gently shake the geophone to trigger the unit and record an event. This confirms that the system is operational.
3. Tap the “Stop Monitoring” button on the touchscreen display or the Cancel key to exit Monitor Mode.

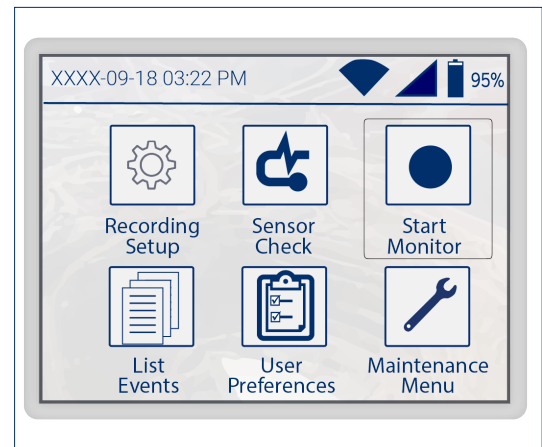

Figure 11

Step 7: View the Event Results

1. Return to the homepage using either the Cancel key or tapping on the Home icon on the top menu. Select the Events List icon on the touchscreen.
2. A list of current events appears. Select the desired event using the arrow keys and the checkmark key or by clicking on the box beside the event time.
3. A new screen appears with the event information. Use the left/right arrow keys to scroll through the channels and the up/down arrow keys to scroll the page data.

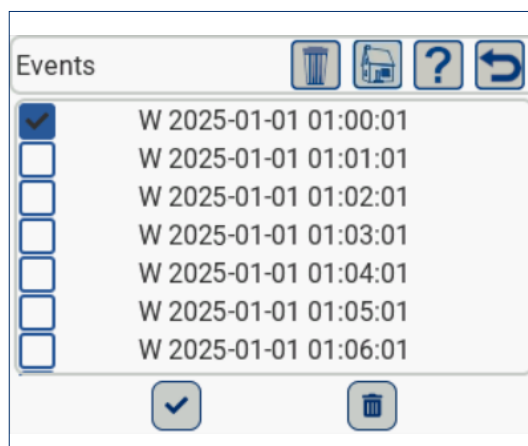

Figure 12

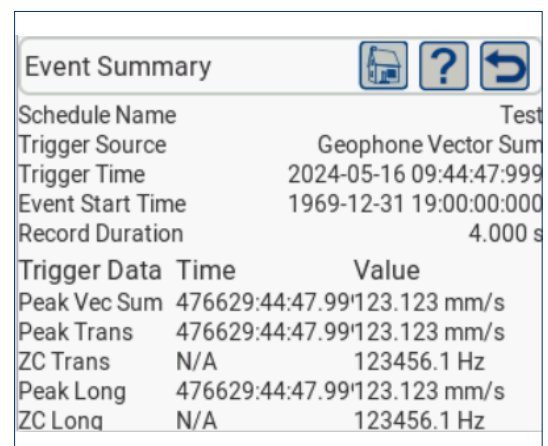

Figure 13

Step 8: Deleting Events

1. Selected events or all events may be deleted in the Events page. To delete events click on the box beside the event. A checkmark appears. Select the Trash icon to delete events.

Note: When connected to Vision II, events are automatically transferred and deleted from the device.

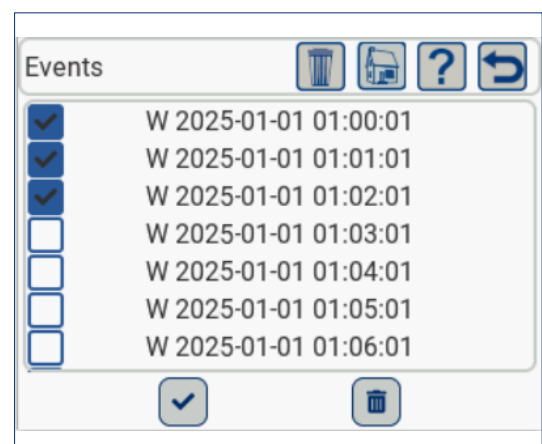

Figure 14





6. Battery Overview

The Micromate Plus monitoring unit's internal lithium-ion batteries, when fully charged, provide up to 20 days of monitoring with battery saving mode enabled. An optional external battery can extend this by an additional 30 days. Please contact your InstanTel dealer for more information.

The Micromate Plus unit has a tamper label located on the side of the case to prevent it from being opened. Attempts to service this product void all warranties offered by InstanTel.

Battery Safety

This product contains an internal lithium-ion rechargeable battery that is not user-serviceable.

-  **Do not attempt to open, replace, or disassemble the battery.**
-  **The battery must be serviced or replaced only by qualified personnel using manufacturer-approved parts. Return the Micromate Plus unit to an authorized InstanTel repair facility should they need replacing.**
-  **Risk of explosion or fire if the battery is mishandled, punctured, or exposed to heat.**
-  **Dispose of the product in accordance with local regulations for electronic equipment and lithium-ion batteries.**

6.1. Battery Life and Temperature

The battery life depends on numerous factors:

Number of events being recorded: High event recording rates use more battery power.

Sample rate: higher sample rates use more battery power. The table below outlines the approximate effects of the sample rate on the battery life.

Ambient temperature: batteries lose their capacity at extreme temperatures. *Battery's age:* batteries degrade over time and may not provide the same capacity as a new battery.

Example: The nominal battery life is 20 days when running in Waveform mode, recording less than 10 one-second events across all four channels, per day, at a sample rate of 1024 SPS with an ambient temperature of 25° C (77° F). (Geophone and linear microphone connected, call-home once daily.)

InstanTel recommends keeping the Micromate Plus monitoring unit on charge when not in use. Any USB device that draws power from the Micromate Plus unit affects the overall battery life.

6.2. Charging the Batteries

The Micromate Plus monitoring unit's internal batteries require regular charging to maintain performance. InstanTel recommends using the supplied 100-240V 50/60 Hz AC adapter with a 12-Volt, 5 Amp (60W) output. To charge the batteries, plug the supplied AC adapter into the connector labeled 12 to 24 VDC PWR and the other end into an electrical outlet. Once connected, the Charging Status LED turns yellow, indicating the unit is connected to an external power source and the internal batteries are charging. The Micromate Plus switches automatically to draw power from either the internal batteries or from the external power source, whichever has the higher voltage.

Solar panels connected via the over molded 12-24V port must be 12V and power 20W to 60W. The Micromate Plus unit limits how much power it will take (approximately 50W peak level.)

Note: Voltage must remain under 30V as the over-voltage protection of the power board is triggered above 30V.

When storing the Micromate Plus unit for long periods, ensure the batteries are charged for at least 24 hours and then disconnected by pressing and holding the power button for 5 seconds.



Warning: Use of AC adapters that exceed the maximum voltage and current specifications may cause undue stress on the monitor's internal regulators. Like all electronic devices, exceeding these specifications increases the risk of damage and possibly accidental fire. The InstanTel warranty does not cover this type of damage.

6.3. Battery Shipping Instructions

Ensure you disconnect the batteries before shipping the unit to InstanTel or an InstanTel Authorized Service and Calibration Facility. Press and hold the power button for five seconds and confirm that you want to disconnect the batteries.



Warning: DO NOT OPEN THE UNIT.

7. Quick Start Guide

This quick start guide provides a quick menu structure. Refer to the detailed information for each menu for complete usage information.

7.1. Common Key Functions

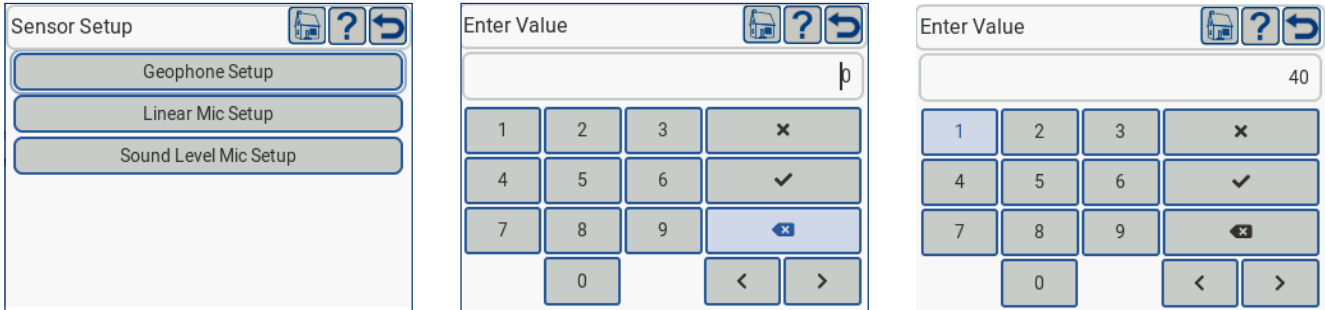

Selecting any clear field with data will open either a keypad (numeric or alphabetical) or a drop-down menu.

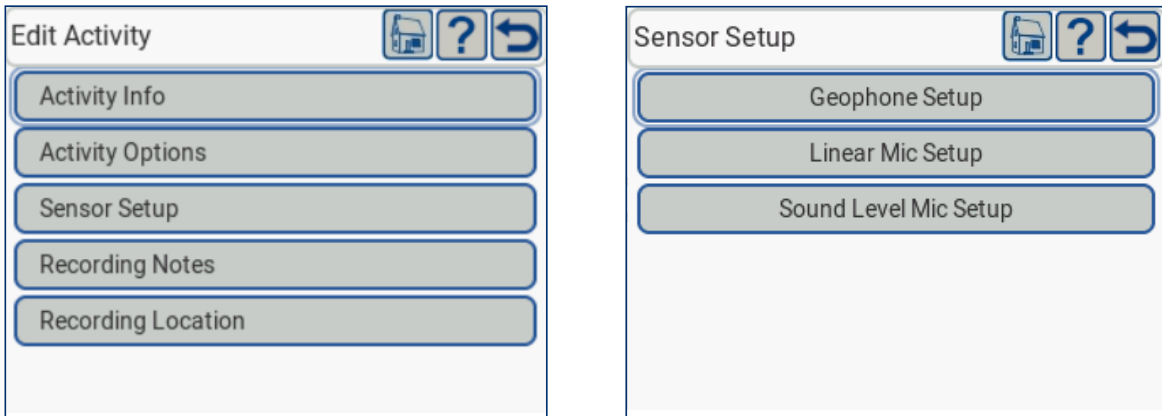

Selecting any field with a grey background will open a new screen and/or additional menu items. Swipe to the right to enable an action (blue fill) or to the left to disable (gray fill).

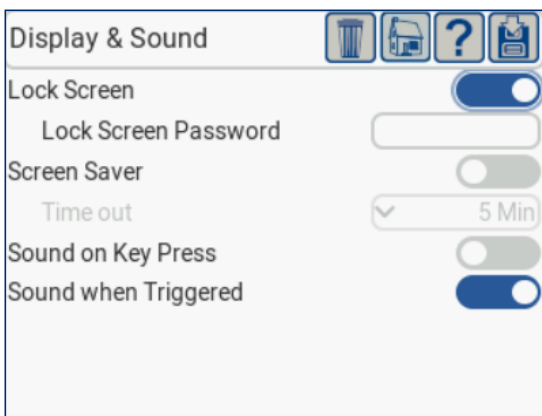

7.2. Recording Set Up

- A. Enable new schedule
- B. Select existing schedule

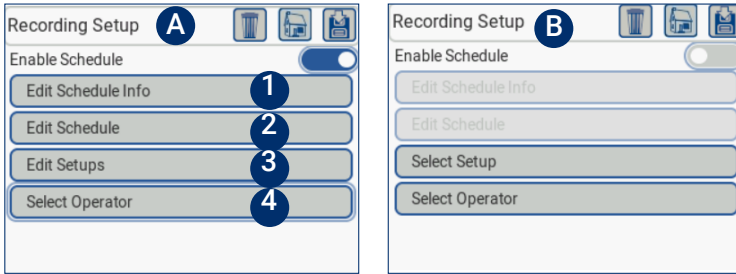
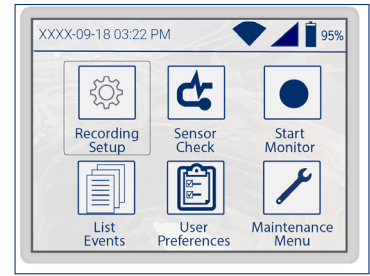

1 Enter schedule name, type and description.

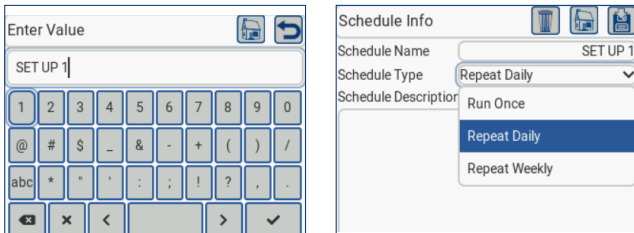

2 Use the + to add a new schedule. A Use the scroll bar to select schedule time. Use the gear icon to adjust a current schedule. B

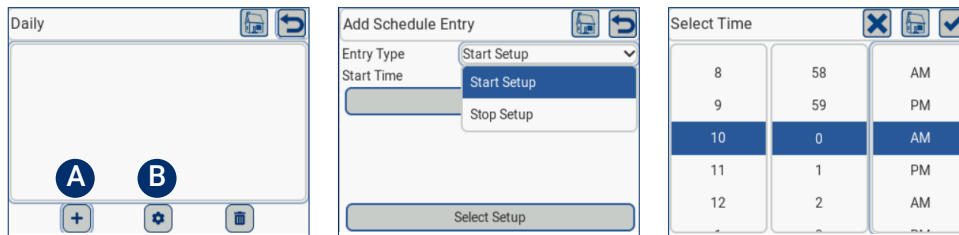

3 Use the + to add a new setup and monitoring type. A Use the gear icon to edit the setup B (See: Edit Setup and Set Up Sensors)

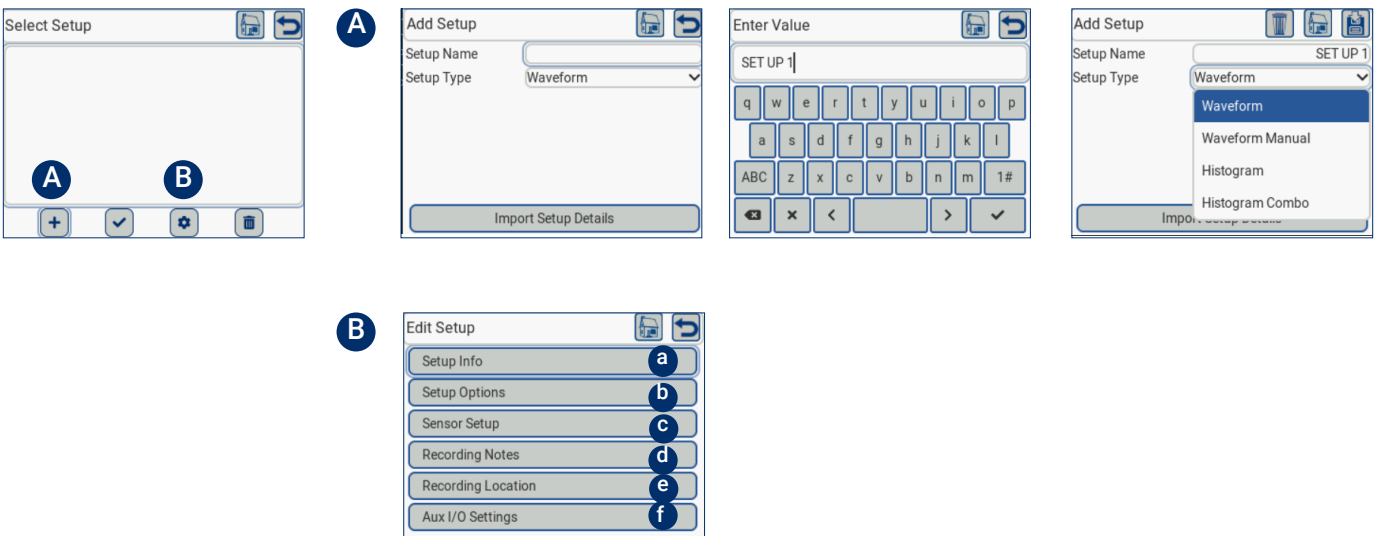

- 4 Use the + to add a new operator or select from existing operators.

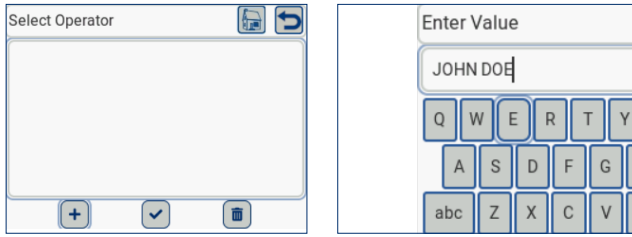

7.3. Edit Setup and Setup Sensors



- a View existing setup file and type or import new setup.

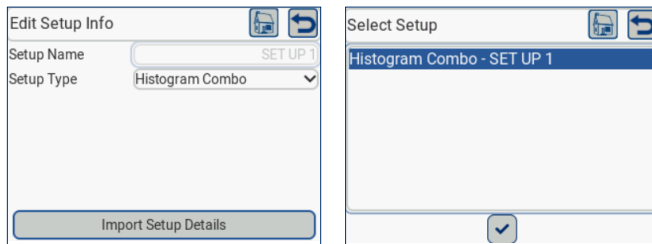

- b Define options: sample rate, pre-trigger, etc.

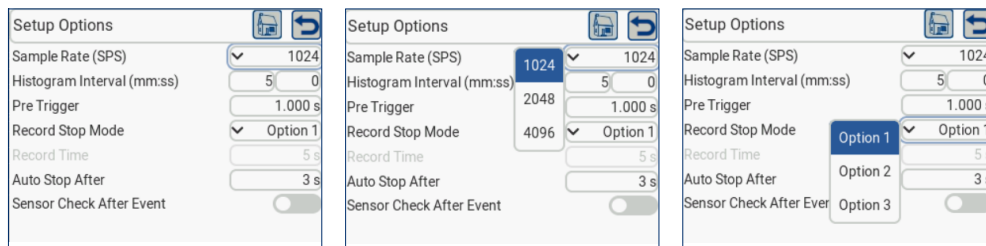

Note: Optional record stop mode allows for preferred record time entry.

- c Setup sensors (geophone, linear microphone and sound level microphone)

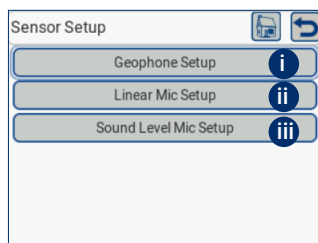

i

ii

iii

Enable trigger, response time, etc.

Enable and define LNs, Leqs.

d Enter recording notes.

e Enter recording location and scaled distance.

f Set up auxiliary sensors.

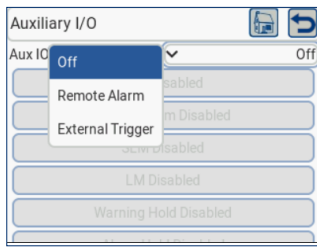

Enable and define remote alarm or external trigger (scroll menu).

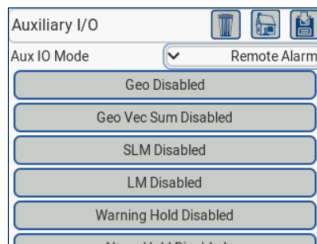

Geo, Geo Vec Sum, SLM, LM

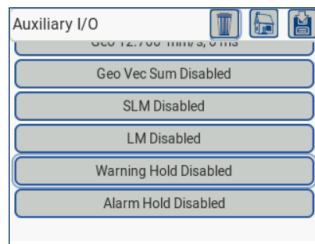

Warning Hold/ Alarm Hold

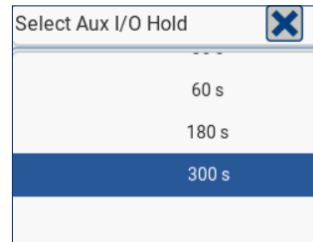
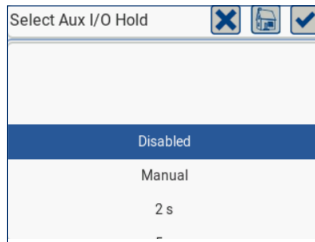
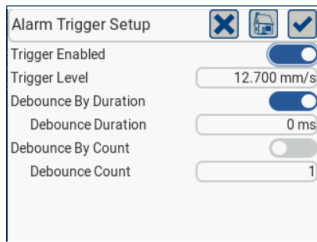

7.4. Perform a Sensor Check

Using the Sensor Check icon.

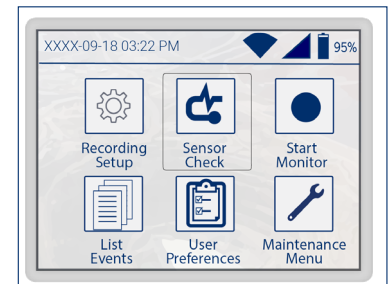

- 1 Tap Start Sensor Check button.
 Pass= Passed
 x = Fail
 N/C = Not connected

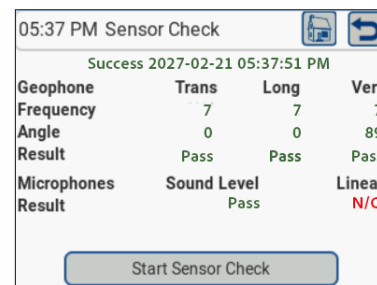
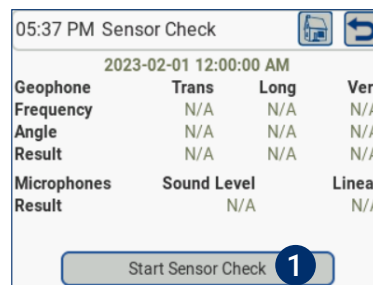

Use the Monitor key to open the monitoring menu.

7.5. Start or Stop Monitoring

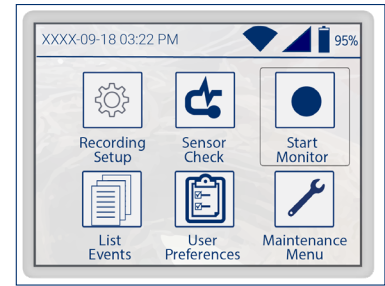

1 Tap Start Monitoring button to start and Stop Monitoring to stop.

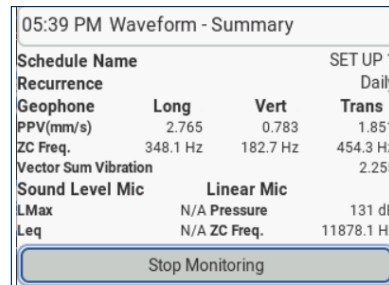
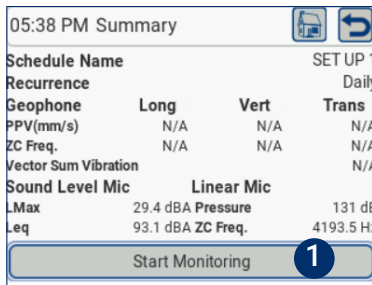

7.6. View or Delete Events

Use the List Events icon to open the event information.

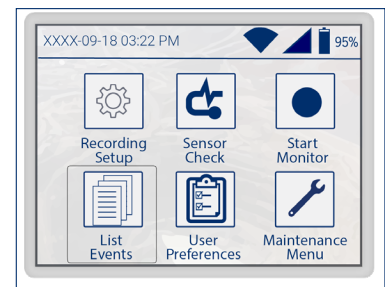

1 Select event and tap the eye at the bottom. Tap trash icon to delete.

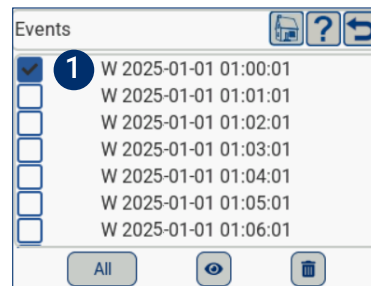
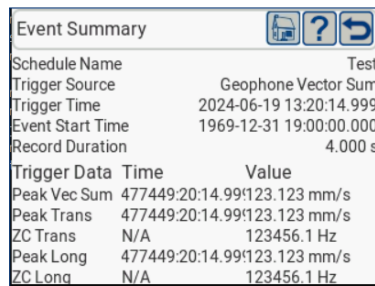

7.7. Set Up Personal Preferences

Use the User Preferences icon to set up preferences for:

- General Preferences
- Connectivity

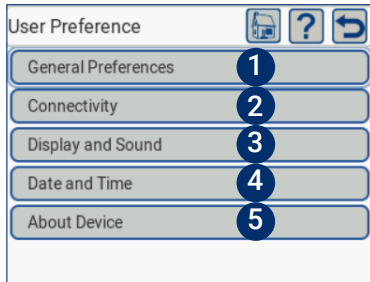
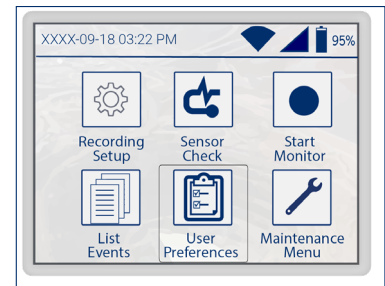

1 Select language, measurement and pressure units.

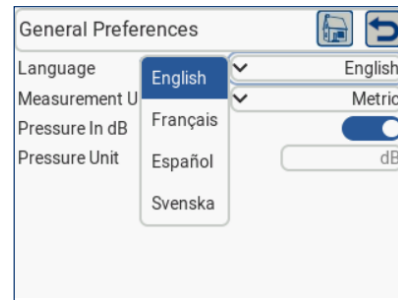
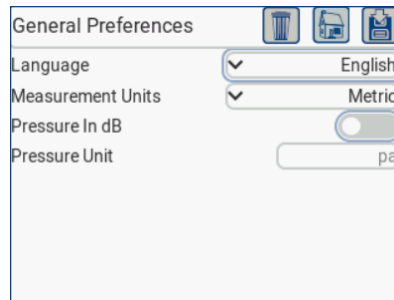
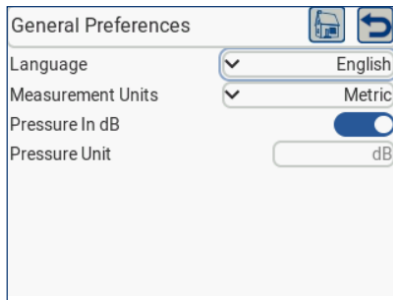

2 Enable connectivity settings and preferences.

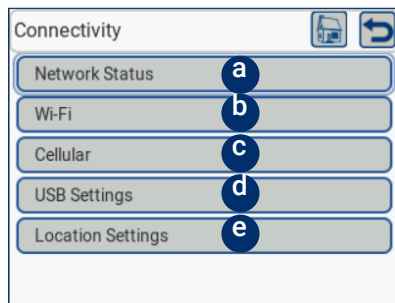

a Network status summary

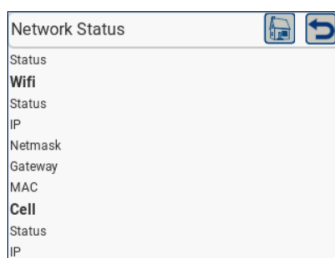

b Enable Wi-Fi/Scan for Wi-Fi network

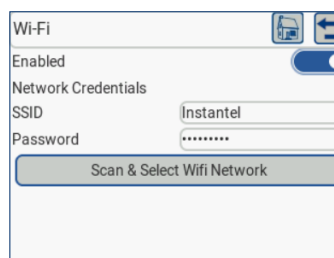

c Enable cellular connection and carrier

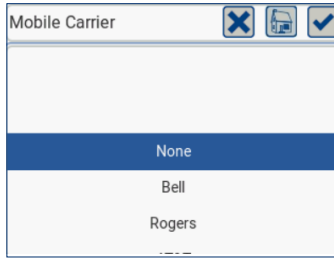
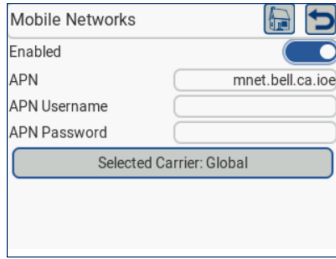

d Enable USB

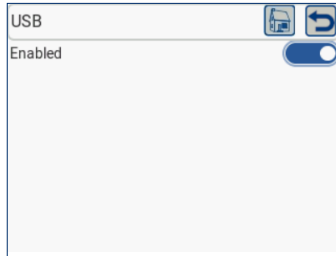

e Enable GPS

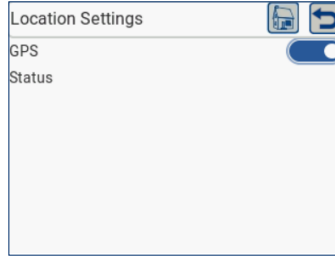

3 Enable display and sound preferences, screen brightness, and timeout.

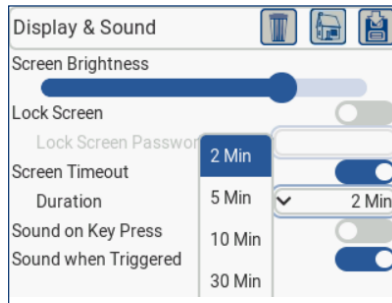
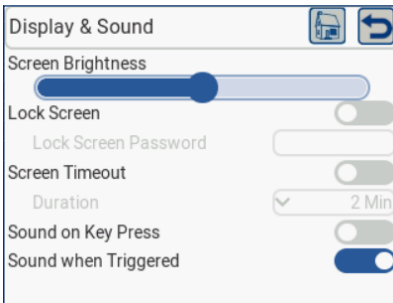

4 Set date and Time and DST.

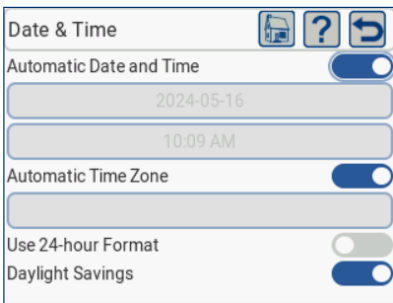

5 Information

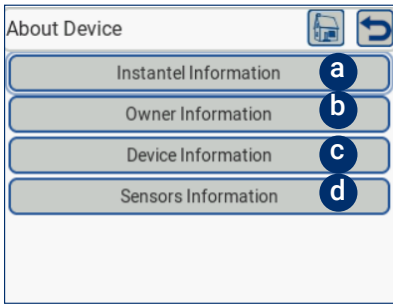

a InstanTel contact information

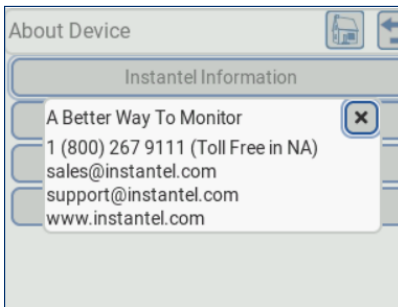

b Owner information



c Firmware version (ensure most recent version is uploaded.)



d Sensor information

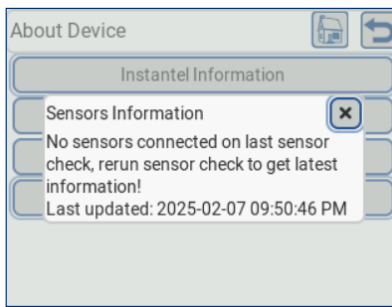

7.8. Unit Maintenance

Use the Maintenance Menu icon to view storage and battery.

1 Storage and battery status.

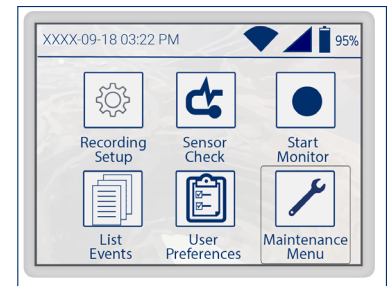
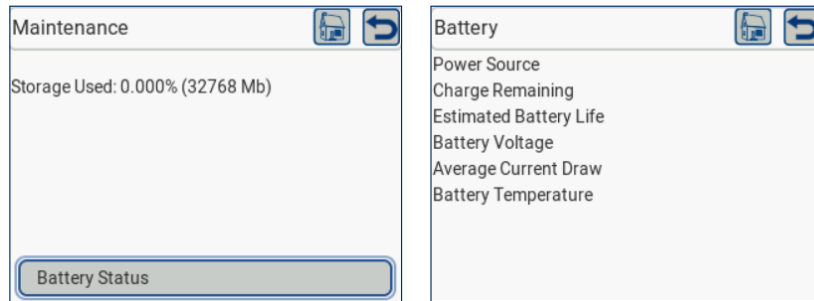

8. Specifications

8.1. General Specifications

Channels:

Channels 1 to 3: Triaxial Geophone

Channels 4 to 5: Sound Level Microphone and Audio Channel

Channel 6: ISEE Linear Microphone or single channel advanced sensor

8.2. Geophone Specifications

	ISEE Mode	DIN Mode
Range	Up to 254 mm/s (10 in/s)	Up to 254 mm/s (10 in/s)
Response Standard	ISEE Seismograph Specification	DIN 45669-1
Resolution	0.00788 mm/s (0.00031 in/s)	0.00788 mm/s (0.00031 in/s)
Frequency Range	2 to 250 Hz	1 to 80 Hz and 1 to 315 Hz
Accuracy	From 2 to 4 Hz and 125 to 250 Hz: +5% to - 3 dB of an ideal flat response, from 4 to 125 Hz: ±5% or ± 0.5 mm/s (0.02 in/s) whichever is greater	
Phase Response	Phase shift from 2.5 to 250 Hz <10% of maximum absolute value of 2 superimposed harmonic vibrations	
Transducer Density	2.3 g/cc (144 lb/ft ³)	
Maximum Cable Length	1000 m (3280.8 ft)	

8.3. Microphone Specifications

	ISEE Linear Microphone	Sound Level Microphone
Weighting Scales	ISEE Linear Microphone	A-Weight or C-Weight
Response Standard	ISEE Seismograph Specification (2022)	Fast (125ms) or Slow (1s)
Range	Up to 1000 Pa (0.145 psi) [154 dB]	30 to 140 dB A or C
Resolution	0.0156 Pa (2.2662x10 ⁻⁶ psi) [0.05 dB]	0.05 dB
Frequency Range	2 to 250 Hz	Up to 20 kHz
Accuracy	2 Hz: -3 dB ± 1 dB, 3 Hz: -1 dB ± 1 dB, from 4 Hz to 125 Hz: ± 1 dB, 200 Hz: ± 1 dB to - 3dB, 250 Hz ± 1 dB to - 4 dB	IEC 61672 Class 1
Maximum Cable Length	75 m (246.1 ft)	75 m (246.1 ft)

8.4. Recording

8.4.1. Waveform Recording

Record Modes	Waveform, Waveform Manual
Storage Capacity	32 GB
Seismic Trigger	0.13 to 254 mm/s (0.005 to 10 in/s)
Linear Acoustic Trigger	2 to 1000 Pa (0.00029 to 0.145 psi) [100 to 154 dB]
Sound Level Microphone Trigger	33 to 140 dB (A or C)
Sample Rate (per channel)	1,024, 2,048, 4,096 S/s (independent of record time)
Record Stop Mode	Fixed record time, AutoRecord™ (see Auto Record time below)
Record Time	1 to 86,400 seconds (plus pre-trigger)
Auto Record Time	An event is recorded until the vibration activity remains below the trigger level for the duration of auto window, or until the available memory is full.
Cycle Time	Recording interrupted by event processing, monitoring, or communication - zero dead time between events.
Full Waveform Events	1 million + 1-second events at 2,048 S/s sample rate

8.4.2. Histogram Recording

Record Modes	Histogram and Histogram-Combo™ (Unit captures triggered waveforms while recording in Histogram mode.)
Recording Interval	From 2 seconds to 100 minutes
Storage Capacity	Histogram: (>12 years at 2-second intervals) 1.8 million 1-second waveform events at 1,024 S/s Histogram-Combo™: >20 years of Histogram recording at 1-minute intervals

8.5. Physical Specifications

Dimensions	20.1 x 11.9 x 8.1 cm (7.9 x 4.7 x 3.2 in) LWH; length dimension includes connectors and dust caps
Unit Weight	2.27 kg (5 lb)
Battery	172 Wh
User Interface	10 domed tactile keys, color touch screen, with display keyboard and dedicated shortcuts for common functions
Display	QVGA, 320 x 240 color touch screen
PC Interface	USB-C
Auxiliary Inputs and Outputs	External Trigger and Remote Alarm
Environmental	
- LCD Operating Temperature	-20 to 55° C (-4 to 131 °F)
- Electronics Operating Temperature	-40 to 55° C (-40 to 131 °F)
- Water Resistance	IP68 - submerge base unit to 30 cm (1 ft) for 24 hours, 1.5 m (4.9 feet) for 1 hour
- Humidity	Up to 95% RH, non-condensing
- Maximum Operating Altitude	5000 m (16404 ft), power adapter: 2000 m (6561 ft)
Remote Communications	Built-in cellular modem and Wi-Fi to automatically transfer events when they occur
Other Features	
-GPS	Factory installed, for time synchronized event data and location stamping
-Vision II	Provides stakeholders with secure, encrypted access to event data, and allows instant sharing for time-sensitive projects
Electrical Standards	CE Class A, FCC Part 15 Class A

9. Enclosing the Unit in a Box

9.1. Recommended Connectors

When enclosing the Micromate Plus in a box, it is important to use the correct connectors. The following connectors are recommended for use with the Micromate Plus. Note: other models are available for use.



Geophone

Recommended models:
 Option 1 - PT07A-12-14S
 Option 2 - PT02A-12-14S
 Cable - InstanTEL Model 727A1101



Option 1



Option 2



Sound Level Microphone

Recommended models:
 Option 1 - PT07A-10-6S
 Option 2 - PT02A-10-6S
 Cable - InstanTEL Model 727A1001



Option 1



Option 2



Linear Microphone

Recommended models:

Option 1 - PT07A-8-4S

Option 2 - PT02A-8-4S

Cable - InstanTel Model 727A0901



Option 1



Option 2



Antenna Extension Cable for Wi-Fi, Cellular, GPS

InstanTel Model 300-100161-000

Antenna Extension Cable (1m cable length)

3 Required (one per antenna)



Power

Recommended models:

Option 1 - PT07A-8-3S

Option 2 - PT02A-8-3S

Cable - InstanTel Model 727A4401



Option 1



Option 2

Note: Connector images may not be exactly as shown (Amphenol or equivalent). InstanTel cabling includes one side open ended and the other with an over-molded connector (for Micromate Plus).



Solar Panel

Solar panels connected via the over molded 12-24V port must be 12V and power 20W to 60W. The Micromate Plus unit limits how much power it will take (approximately 50W peak level.) Note: Voltage must remain under 30V as the over-voltage protection of the power board is triggered above 30V.



⚠ WARNING: Do not connect 24V solar panels as they produce voltages much higher than the 30V limit and may damage the unit. Only use 12V solar panels.



Supplemental charging is also available through the USB-C port.



The World's Most Trusted

Vibration • Noise • Air Overpressure • Remote Monitoring • Cloud-Based Data Management • Calibration • Repairs • Software Solutions

www.instantel.com

Canada (Headquarters)
309 Legget Drive
Ottawa, Ontario K2K 3A3

United States
808 Commerce Park Drive
Ogdensburg, New York 13669

Telephone: 1.613.592.4642
Toll-Free Telephone: 1.800.267.9111 (North America Only)
Email: sales@instantel.com