

Remote Alarm Controller for Micromate® and Series III Monitors

Purpose

This technical bulletin describes the procedures for installation and use of the optional **Remote Alarm Controller** for the **Micromate** (Part No. 721A0901), **Minimate Plus™** or **Blastmate III™** (Part No. 721A0902) Series III units.

Explanation

The **Remote Alarm Controller** is used to indicate when the seismograph has exceeded its preset monitoring trigger levels for a **Warning** signal and dedicated alarm level triggers for a secondary **Alarm** level signal. The trigger level settings can be configured based on the specific sensors you have connected to the seismograph. The secondary **Alarm** trigger levels must be set higher than the **Warning** trigger levels.

For example, in pile driving operations when monitoring ground vibration only, the remote alarm triggers a **Warning** level signal to notify the operator that the pile driving activity has exceeded the preset monitoring trigger level and appropriate action and attention may be required. If the secondary **Alarm** triggers, when activity exceeds the dedicated **Vibration Alarm Trigger Level**, the operator is notified that operations should cease immediately.

The remote alarm outputs are isolated from the seismograph using normal open relay contacts. These relay contacts are capable of switching loads up to 2 amps and 24 volts DC.

If the remote alarm controller cannot be located close to the seismograph you can use an optional extension cable to extend the distance between the seismograph and **Remote Alarm**. The connections from the remote alarm output terminals to the alarm device(s) can also be extended over long distances providing there is enough voltage available for the alarm device.

Equipment Required

1. Micromate, Minimate Plus, or Blastmate III
2. Remote Alarm Controller (Part No. 721A0901 for Micromate) (Part No. 721A0902 for Series III)
3. Optional Micromate Extension Cable:
 Part No. 721A0801: 100 ft. (30.5 m)
 Part No. 721A0802: 250 ft. (76.2 m)
 Optional Series III Extension Cables:
 Part No. 714A3801: 100 ft. (30.5 m)
 Part No. 714A3802: 250 ft. (76.2 m)
 Part No. 714A3805: Custom Length
4. External Alarm with power source (required - not supplied)

Installation of the Remote Alarm

Connecting to the Monitor

Connect the **Remote Alarm Controller** to the **AUXILIARY** connector on the unit. An optional, compatible extension cable may be used to increase the distance between the **Remote Alarm Controller** and the monitor.

Alarm Connection

The output post available on the terminal block is a switch only. The user must supply the external power to drive the load. When using an external warning device, the common terminal is the ground or minus side of the external load-power source combination. Normally, one side of the load connects to one of the outside terminals, the other side of the load connects to the positive side of the power supply. The negative side of the power supply connects to the common terminal.

Monitor Setup

Refer to the Remote Alarm section within the product manual for information on how to setup the monitor.

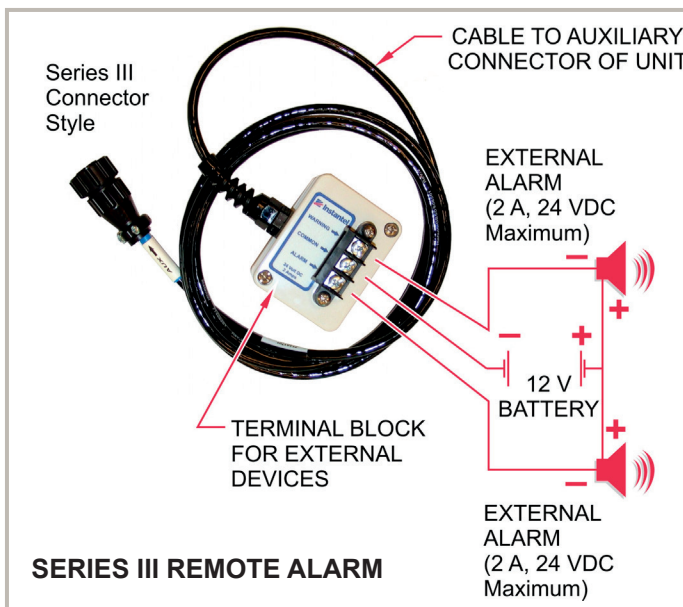
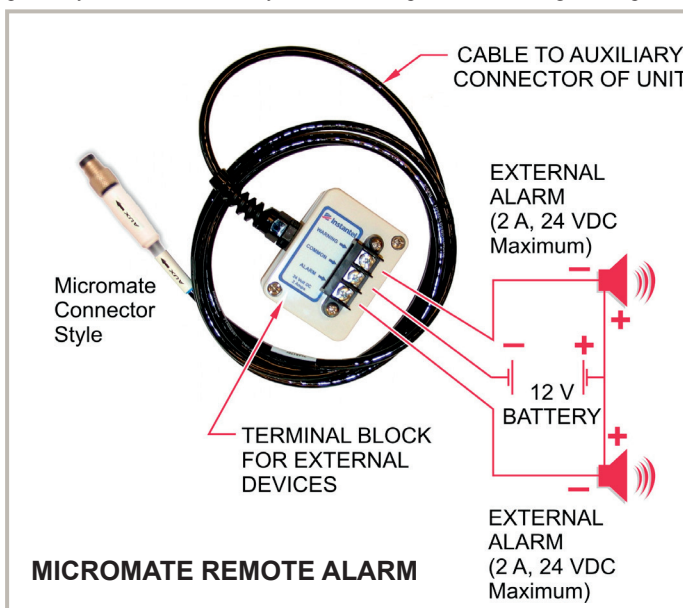

Warranty

InstanTEL's products are warranted against defects in materials and workmanship and shall perform in accordance with published specifications for a period of ninety days. This warranty is void if the protective heatshrink is removed from the cables. The company makes no warranty, expressed or implied of fitness for purpose, merchantability or function of the products. InstanTEL does not represent that any product will prevent bodily injury or damage to property.

Should a product fail to operate to these specifications within the warranty period it shall be repaired or replaced free of charge. This warranty is void if the equipment has been dismantled, altered or abused in any way. Authority to return the product must be obtained from InstanTEL prior to shipment. Shipping charges to InstanTEL's factory will be paid by the customer and InstanTEL shall pay for the return freight.

InstanTEL assumes no responsibility for damages of any description resulting from the operation or use of its products. Since it is impossible to anticipate all of the conditions under which its products will be used, either by themselves or in conjunction with other products, InstanTEL cannot accept responsibility for the results unless it has entered into a contract for services which clearly define such an extension of responsibility and liability. InstanTEL retains the right to change specifications without notice.

EC Warning

This is a Class A product. In a domestic environment this product may cause radio interference in which case the user may be required to take adequate measures.



Corporate Office:
309 Legget Drive,
Ottawa, Ontario K2K 3A3
Canada

US Office:
808 Commerce Park Drive,
Ogdensburg, New York 13669
USA

Toll Free: (800) 267 9111
Telephone: (613) 592 4642
Facsimile: (613) 592 4296
Email: sales@instanTEL.com

© 2016 Xmark Corporation. InstanTEL, the InstanTEL logo, Blastmate, Blastware, Micromate and Minimate are trademarks or registered trademarks of Stanley Black & Decker, Inc., or its affiliates.

StanleyBlack&Decker

721U0901 Rev 03 - Product Specifications are Subject to Change